



SERVICE BULLETIN No. 1088

Circulate to listed addressees

COACH MODEL	: T800 Series; T900 Series; T 2100 Series; C2045
BULLETIN TYPE	: Service Information
MANUAL & SECTION	: Maintenance Manual: Chapter 5 - Brakes
DATE	: May 7th, 2003
SUBJECT	: Automatic slack adjusters on drive axles featuring drum brakes
TERMS & CONDITIONS	: No claims will be accepted with reference to this Bulletin.

APPLICATION:

The procedure subject of this Bulletin is applicable to coaches with drum brakes on the drive axle.

Disc brakes have been introduced on the drive axle as from following units:

Coach type	Model	Engine	VIN
Touring	T2145	Cummins	44055
		Detroit Diesel	43945
Commuter	C2045	Cummins	45137
		Detroit Diesel	45621

DESCRIPTION:

To ensure optimum operating efficiency of the brake system, proper maintenance on a predetermined schedule is essential. Both the mechanical and air subsystems must be checked systematically, and measures taken as required. The Van Hool Maintenance Manuals contain detailed preventive procedures to ensure optimum brake system performance and acceptable service life. This Bulletin is issued in an effort to stimulate regular brake system maintenance, and to recapitulate the necessary inspection and adjustment instructions of the drive axle brakes, which are equipped with automatic slack adjusters. These adjusters have a fixed shoe-to-drum sensor built into them. The key to successful brake adjuster performance is simply to follow the recommendations below.

Service personnel: please read, initial and circulate.

Service Manager	Parts Manager	Warranty Administrator	Workshop Foreman	Service Technician

PROCEDURE:

CAUTION: Observe safe shop practices at all times. Read the entire procedure before beginning to work.

1. Brake system maintenance intervals:

- **After the first 3,000 miles (this includes after rebuilding the brakes):**

- Check brake operation.
- Check brake chambers valves, lines and fittings for air leaks.
- Lubricate drive axle brake S-cam bushings.
- Lubricate drive axle brake push-rod clevis pins.

- **Every 5,000 miles (C-interval):**

- Check brake operation and measure brake chamber throw (refer to the service procedure further in this Bulletin).

CAUTION: When the brake chamber throw is out of range, either the control arm/bracket may be loose or broken, or the slack adjuster may be faulty.

- Lubricate drive axle S-cam bushings.
- Lubricate drive axle brake push-rod clevis pins.

- **Every 10,000 miles (C-interval):**

- Check brake lining wear.
- Check brake chambers for condition and leaks.
- Check brake system valves, lines and fittings for leaks.
- Lubricate brake pedal pivot pin.

- **Every 180,000 miles (G-interval):**

- Replace brake chamber diaphragms

2. Brake system maintenance:

CAUTION: Before doing any maintenance, block wheels to prevent vehicle movement.

- **To check brake operation**

Perform these checks at the intervals given in the maintenance schedule. These checks require the aid of an assistant.

- 1) Connect an accurate air pressure gauge to the test fitting in the air line leading to the right-hand drive axle service brake chamber.
- 2) Apply the brakes to 90 psi and hold. Check all air lines, fittings and air chambers for leaks.
- 3) Apply and release the brakes while observing the operation of the slack adjusters. As the brakes are applied and released, the slack adjusters should move with the push-rods.

- **To lubricate the S-cam bushings**

At the intervals given in the maintenance schedule, lubricate the S-cam bushings through the grease fittings located on the brake chamber mounting bracket assembly.

- **To lubricate the slack adjusters**

- 1) Slack adjusters, manufactured by Haldex and OE fitted with a grease nipple, should be lubricated with Standard Chassis Grease every 5,000 miles or every 3 months, whichever comes first.

NOTE:

Do not mix Haldexol and EP type grease.

Moly-disulfide grease should not be used because it can shorten the service life of the automatic brake adjuster.

In no case should the lubrication interval exceed the published interval above.

- 2) No-Lube slack adjusters, manufactured by Haldex, are lubricated at the factory with Haldexol Propriety Grease and **SHOULD NOT** be lubricated. A hex plug has been installed into the adjuster casting to replace the grease fitting. Do not remove the grease plug. Contact Haldex if uncertain or if requiring additional information.

- **To measure brake chamber throw (see Figure 1)**

This is one of the most important functions to determine static performance of the pneumatically operated drum brake. It is a must activity to be done prior to a brake re-line, or every 5,000 miles.

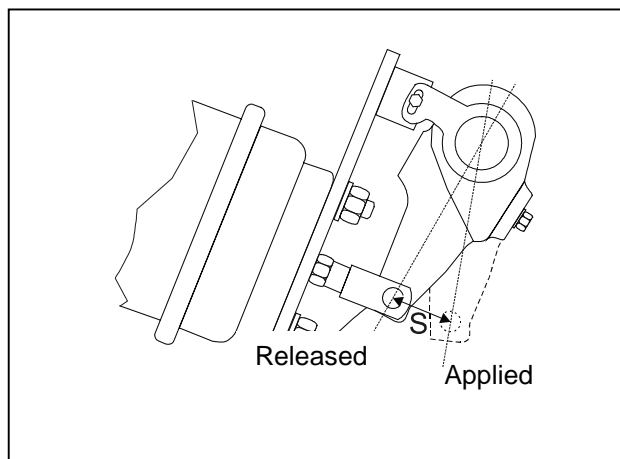

Figure 1: Brake chamber throw

- 1) Block the wheels, if on the ground, and/or release the parking brake, if on a hoist.
- 2) Connect an accurate air pressure gauge to the test fitting in the air line leading to the right-hand drive axle service brake chamber.
- 3) Bring the system air pressure to between 90 and 100 psi and shut off the engine.
- 4) Depress the brake pedal, until the test gauge shows 90 psi and have an assistant measure the corresponding brake chamber throw to within 1/16th inch. Record the

measurement on the inspection sheet. The correct brake chamber throw is 2 inches plus or minus 10%.

If the chamber throw exceeds the maximum range mentioned above, a repair action is needed. Do not manually adjust the automatic slack adjuster.

CAUTION: Manual adjustment of the automatic slack adjuster could shorten its clutch life and may void the warranty.

Check that the control arm and bracket are free of cracks and firmly attached, and that mounting bolts are tightly secured. If these items check out OK, the slack adjuster is out of order. To determine whether the adjuster needs replacement, turn the adjusting hex nut counterclockwise with a torque wrench as explained in "To check de-adjustment torque". If torque is less than 15 ft.lbf, replace the adjuster. If torque exceeds 15 ft.lbf, inspect the brake for worn parts and repair.

- **To check brake adjustment**

The brakes have been provided with automatic slack adjusters. After brake shoe replacement, the initial travel of the automatic adjusters should be hand-set as follows:

- 1) With the parking brake OFF, turn the slack adjuster's hexagon head, rotating the camshaft, until travel 'S' (see Figure 1), measured under full operating pressure equals 2.3 inches.
- 2) After applying maximum air pressure to the brakes about 20 times, check whether the pushrod travel decreases, which indicates proper action of the adjusting mechanism.
- 3) Travel will then further decrease to approximately 2 inches some time after the vehicle has returned into service.

- **To check lining wear**

At intervals given in the maintenance schedule, check lining wear. A visual check of lining thickness and condition must be made. The lining should be replaced, if worn or less than ¼ inch at any point.

3. Automatic slack adjusters:

- **Purpose**

The purpose of the automatic slack adjuster is to compensate for brake lining and drum wear without the need for service attention.

- **To inspect**

Clean and visually inspect slack adjusters, control arms and anchor brackets for tightness and damage.

- **To check de-adjustment torque**

- 1) Place a torque wrench on the adjusting hex.

- 2) Turn the torque wrench counterclockwise and check that the clutch does not slip at a torque of less than 15 ft.lbf. A ratcheting sound will occur when backing off. If the clutch slips at a lesser torque, the adjuster must be replaced.

- **To install (see Figure 2)**

- 1) Block the wheels to prevent the coach from rolling.
- 2) Check that the chamber pushrod is fully retracted (brake chamber face to clevis pin centerline: approximately 3.15 inches).
- 3) Lubricate the end of the camshaft lightly with graphite-grease. This will ease future slack adjuster removal, if necessary.
- 4) Install spacer (2) on camshaft (1).
- 5) Slide the slack adjuster (15) onto the camshaft so that the slack adjuster arm is as near as possible to the pushrod yoke (16).

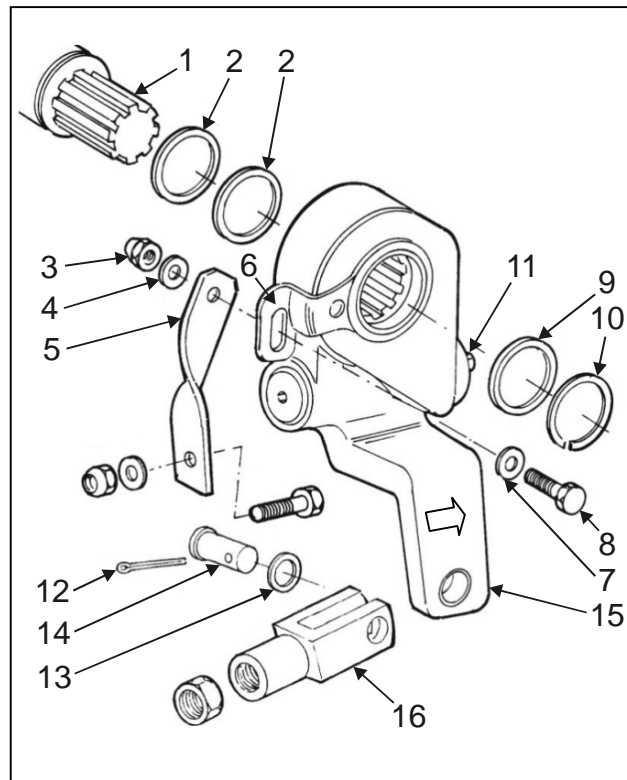

Figure 2: Slack adjuster installation – exploded view

1. Brake camshaft
2. Spacer
3. Self-locking nut
4. Washer
5. Anchor bracket
6. Control arm
7. Washer
8. Bolt
9. Spacer
10. Snap ring
11. Adjusting hex
12. Cotter pin
13. Washer
14. Clevis pin
15. Slack adjuster (arm)
16. Pushrod yoke

CAUTION: The slack adjuster must be installed on the camshaft with the arrow on the housing pointing in the direction of brake application.

- 6) Install spacer (9).
- 7) Secure the slack adjuster with snap ring (10).
- 8) Turn the adjusting hex (11) clockwise, until the clevis pin hole in the slack adjuster arm lines up with the clevis pin hole in the pushrod yoke (16).

- 9) Lubricate and install clevis pin (14). Do not install cotter pin (12) yet.
- 10) Rotate the slack adjuster control arm (6) in the direction of the arrow on the slack adjuster arm (15), until it comes to a positive stop. It is important for proper slack adjuster operation that the control arm is maintained in this position. Do not hammer on the control arm.

CAUTION: When securing the slack adjuster control arm to the anchor bracket, make sure the control arm does not become distorted (see Figure 3). Be sure the anchor bracket is fitted perfectly parallel to the slack adjuster control arm.

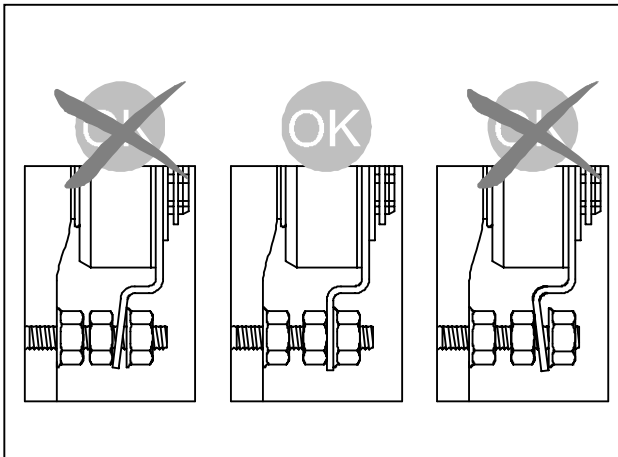

Figure 3: When doing up the mounting bolts, control arm should not be distorted

CAUTION: When the control arm is not firmly against the internal stop, the free-running clearance is insufficient.

Position bolt (8) into the control arm slot and tighten securely. Check the correct position of the control arm as follows: remove clevis pin (14) temporarily and, manually, try to push the slack adjuster arm towards the brake chamber. If this is possible, loosen bolt (8) and repeat steps 9 and 10.

- 11) Install washer (13) and cotter pin (12). Bend over the cotter pin legs.
- 12) Hand-set the initial travel of the automatic slack adjuster as explained elsewhere in this Bulletin under "Brake system maintenance – To check brake adjustment."

4. Facts about automatic slack adjusters:

- Do not manually adjust slack adjusters for any reason, other than initial adjustment after brake overhaul.
- Never use an impact wrench to adjust or internal slack adjuster damage will occur.
- Manual brake adjustments may void the slack adjuster warranty.
- When in doubt about the type of slack adjuster used on a vehicle, always refer to the manufacturer's recommendations.

- When checking automatic slack adjuster operation, three actions are always required:
 1. Measure the brake chamber throw per CVSA/DOT requirements.
 2. Grease the adjuster, if required (see: "To lubricate slack adjusters").
 3. Inspect the control arm and bracket for integrity.
- Automatic slack adjusters need not be replaced in pairs.
- When re-lining brakes, remove the slack adjuster from the S-cam shaft and rotate the worm wheel 90° before refitting. This prevents the gear wheel from operating in the same range all the time and reduces wear of the worm shaft.
- Do not mix types of adjusters on the vehicle.
- Before replacing an automatic slack adjuster, check to make sure that the bracket is connected firmly to the adjuster control arm. A loose bracket will result in a long throw.
- Each adjuster needs to be inspected at each scheduled maintenance period.
- Automatic slack adjusters are non-serviceable items and should be replaced with OEM spare parts, whenever found faulty.

Procedure complete.

***NOTE:** Van Hool coaches provided with OE drum brakes on the drive axle, are equipped with automatic slack adjusters manufactured by the Haldex Brake Products Corporation (Haldex). Coaches with disc brakes on the drive axle, however, are not fitted with these slack adjusters.*

SERVICE INFORMATION:

Service Bulletins are issued to supplement or supersede information in the Van Hool manuals. Note Service Bulletin number, date and subject on the register at the end of the relevant chapter(s). File Service Bulletin separately for future reference.

THIS PAGE HAS BEEN LEFT BLANK INTENTIONALLY