



SERVICE BULLETIN No.1149

Circulate to listed addressees

COACH BUS MODEL	: T900, T&S 2100, C2000 Series
BULLETIN TYPE	: Service Information
MANUAL & SECTION	: Maintenance Manual: Chapter 8 - Suspension Spare Parts Manual: Section 642xxx - Axles
PARTS BOOK REVISION	: No
DATE	: September 2, 2004
SUBJECT	: Suspension mounting bolts
TERMS & CONDITIONS	: No claims will be accepted with reference to this Bulletin.

APPLICATION:

The service information subject of this Bulletin is applicable to Van Hool units with independent suspension.

DESCRIPTION:

1. Suspension mounting bolts

The purpose of this Bulletin is to remind customers that the Maintenance Schedule calls for specific service requirements for suspension component fasteners.

The bolts securing the suspension wishbones to the chassis need to be checked for tightness at regular intervals.

Failure to check the bolt torque, reuse of the self-locking nuts and wrongly installed shims during suspension system service may affect the useful service life of these bolts.

To address the issue, the procedure in this Bulletin reviews how and when to check and properly torque these critical fasteners.

2. Preventive maintenance schedule

The preventive maintenance schedule is a compilation of suggested maintenance operations contained in the Maintenance Manual. Some maintenance intervals must be determined by shop personnel based on operating conditions, component failure history and previous experience.

Service personnel: please read, initial and circulate.

Service Manager	Parts Manager	Warranty Administrator	Workshop Foreman	Service Technician

PARTS AND PRODUCTS:

Part No.	Description	Qty.
VH 10546442	Bolt, wishbone mounting, M16 x 1.5 x 95 mm, grade 10.9	#
VH 660251271	Bolt, wishbone mounting, M16 x1 .5 x 100 mm, grade 10.9	#
VH 660251290	Bolt, wishbone mounting, M18 x 1.5 x 180 mm, grade 10.9	#
VH 10707778	Bolt, wishbone mounting, M18 x 1.5 x 190 mm, grade 10.9	#
VH 660207214	Nut, self-locking M16 x 1.50 mm, grade 10	#
VH 660207287	Nut, self-locking M18 x 1.50 mm, grade 10	#
VH 614306500	Shim, wishbone to chassis, alloy steel, 5 mm, to suit 16 mm bolt	#
VH 614306480	Shim, wishbone to chassis, stainless steel, 1 mm, to suit 16 mm bolt	#
VH 614306490	Shim, wishbone to chassis, stainless steel, 2 mm, to suit 16 mm bolt	#
VH 614308800	Shim, wishbone to chassis, alloy steel, 5 mm, to suit 18 mm bolt	#
VH 614308780	Shim, wishbone to chassis, stainless steel, 1 mm, to suit 18 mm bolt	#
VH 614308790	Shim, wishbone to chassis, stainless steel, 2 mm, to suit 18 mm bolt	#
VH 10580795	Washer, to fit beneath M16 self-locking nut	#
VH 660631904	Washer, to fit beneath M18 self-locking nut	#

- Parts may be purchased from your nearest ABC Customer Care & Parts Source dealership.
- Parts and products disposition: discard according to applicable environmental regulations.

***NOTE:** When selecting new fasteners for repair, always use fasteners with the same dimensions and of the same grade as originally installed.*

PROCEDURE:

1. General:

- This job should be executed by a technician experienced in suspension system maintenance.

2. Maintenance interval recommendations:

WISHBONE MOUNTING BOLT TORQUE CHECK		
Maintenance interval	Check torque	Action
Pre-delivery inspection (new coaches only)	OK	Re-check at 3,000 miles
	Not OK	Re-torque to spec. Re-check at 3,000 miles
3,000 miles (new coaches only)	OK	Re-check at 6,000 miles
	Not OK	Re-torque to spec. Re-check at 6,000 miles
6,000 miles	OK	Re-check at 12,000 miles
	Not OK	Replace fasteners and shims Re-check at 6,000 miles after repair*
12,000 miles	OK	Re-check at 60,000 miles
	Not OK	Replace fasteners and shims Re-check at 6,000 miles after repair*
60,000 miles	OK	Re-check every 60,000 miles
	Not OK	Replace fasteners and shims Re-check at 6,000 miles after repair*

*Applicable to all service activities which include undoing/re-tightening of the wishbone fasteners.

2. Special tools, equipment or services:

- This job requires the use of an accurate torque wrench. For better access to the nuts and to facilitate the torque check, a crowfoot wrench may be used.

CAUTION: When using a crowfoot wrench to check the tightness of the wishbone mounting bolts, make sure that the proof load of the tool exceeds the torque applied.

3. Preparations:

- Park the coach on a level-surfaced service pit with the front wheels straight. If portable post lifts are going to be used, lower the suspension first. Apply the parking brake and shut down the engine.
- Switch off all systems and turn off the battery master switch.
- Put a "DO NOT OPERATE" tag on the instrument panel.
- Read the entire procedure before beginning to work.

CAUTION: Observe safe shop practices at all times.

4. To check and tighten the suspension suspension mounting bolts after the first 6,000 miles, or 6,000 miles after removal or repair of the suspension components:

Job time estimate: approximately 0.5 hours.

NOTE: Bolt torque should be checked at the nut, not at the bolt head.

When working with suspension bolts or nuts, bolts may be reverse-installed with the head pointing towards the coach exterior for easier access to the nuts.

This is particularly useful at the tag axle (see Figure 4).

NOTE: When replacing/exchanging the 13/64 inch (5 mm) shims at the wishbones for wheel alignment, it is required to use the new laser cut alloy steel shims in lieu of the early carbon steel ones (see Figures 1 and 2).

3/64 and 5/64 inch (1 and 2 mm) stamped stainless steel shims can still be used as before. Suspension alignment shims must be straight and of the same overall thickness, to ensure proper and lasting adjustment of the wheel position.



Figure 1: Stamped 5 mm carbon steel shims show unequal thickness and are no longer recommended for accurate suspension alignment purposes

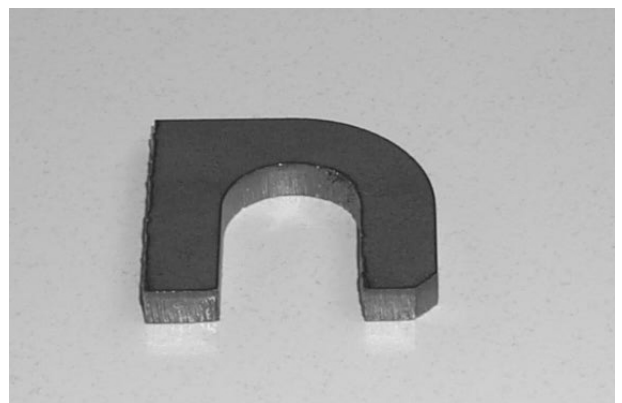

Figure 2: Laser cut 5 mm alloy steel shims are better suited for accurate adjustment of the wheel position

- 1) Using a torque wrench check that the torque required to turn the nuts of the wishbone mounting bolts complies with the torque figures of the Maintenance Manual (see Figures 3 and 4).

Figure 3: Front axle suspension wishbone – mounting bolt recommended torque figures (note bolt orientation)

1. 245-325 ft.lbf (4 nuts)
2. 205-225 ft.lbf (8 nuts)

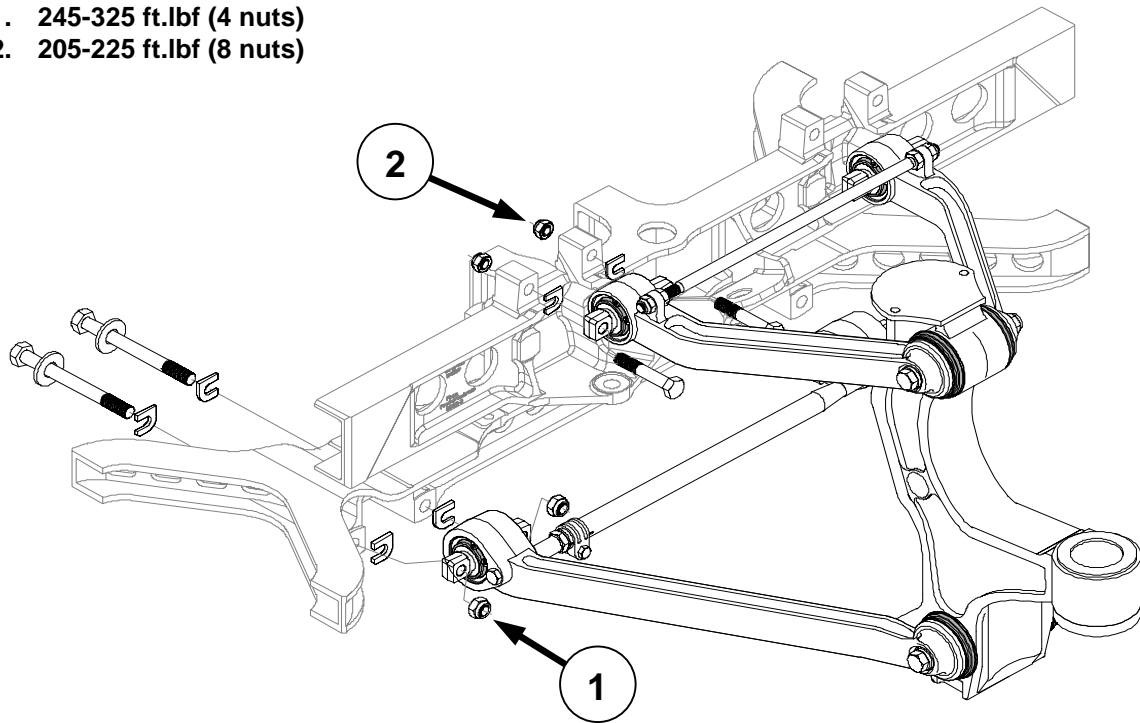
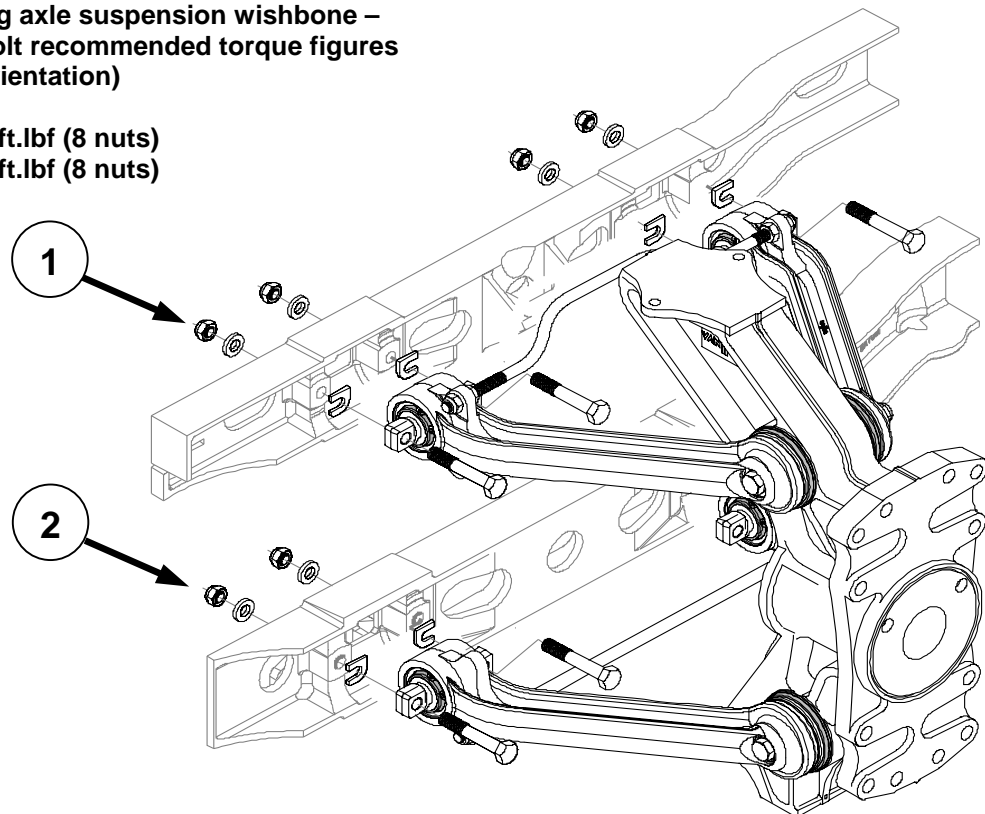

Figure 4: Tag axle suspension wishbone – mounting bolt recommended torque figures (note bolt orientation)

1. 205-225 ft.lbf (8 nuts)
2. 205-225 ft.lbf (8 nuts)



- 2) Refer to “2. Maintenance interval recommendations” in this Bulletin.
If the chart calls for replacement of fasteners and shims, undo and remove the nut of the affected bolt. Discard the nut.
- 3) Tap out the affected bolt using a drift. Recover the suspension adjusting shim(s) - see Figure 5.
- 4) Inspect the affected bolt for damage. Any nicks, burrs, necking down, buckling, or damage to the thread render it useless. Replace by new if damaged.
Discard damaged hardware, so it cannot be re-used.
- 5) Check that the boltholes line up and that they are square and true. Adjust if necessary.
- 6) Carefully inspect the shims for signs of deterioration.
Check that the shims are undamaged and true.
Replace as required by new shims to obtain the same thickness.
Discard damaged hardware, so it cannot be re-used.
- 7) Referring to Figures 3 and 4 for bolt orientation (re-) install the bolt and shims.
Make sure the shims are installed horizontally, and in an identical manner with the open end pointing as shown in Figure 5.

NOTE: *Shims should be installed horizontally to provide equal support to the bushing shaft bar on the vertical axis. The up and down motion of the suspension induces a rocking on the bushing which needs to be opposed by the shims. The horizontal installation of the shims provides for the largest contact with the bushing shaft to absorb the rocking*

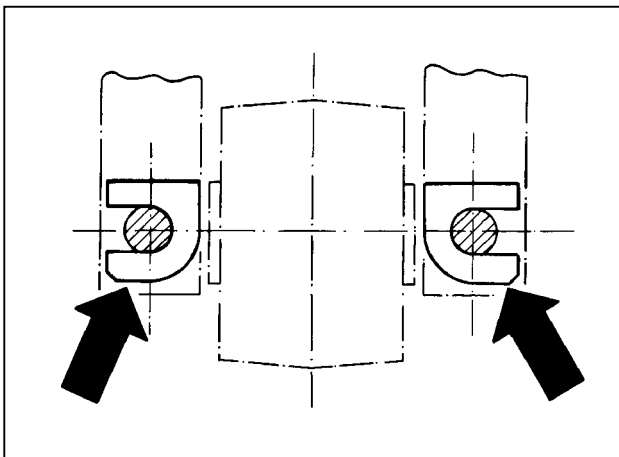

Figure 5: Correctly installed shims as per Van Hool Maintenance Manual

- 8) At the tag axle, install washer VH 10580795 (M16) before running up a new self-locking nut. The washer should fit between the nut and the machined cast steel surface of the coach structure to protect it from damage while tightening the nut.
- 9) At the front axle, fit washer VH 660631904 (M18) under the bolt head of the lower wishbone mounting bolt to prevent interference of the bolt thread and the wishbone tie rod.
- 10) Using a torque wrench, bring up the nut hand tight.
- 11) Undo and remove the nut of the bolt adjacent to the affected bolt. Discard the nut. Repeat steps 2 through 9.
- 12) Using a torque wrench and alternating between bolts go over the nuts again bringing to two-thirds torque. They should then be brought to full torque. A fourth time over will make sure both are within specification. Remember that proper torque is a **MUST**.

Procedure complete.

DISCLAIMER:

The procedures contained herein are not exclusive. Van Hool cannot possibly know, evaluate, or advise the transportation industry of all conceivable ways in which a procedure may be undertaken or of the possible consequences of each such procedure. Other procedures may be as good, or better, depending upon the particular circumstances involved.

Each carrier who uses the procedures herein must first satisfy itself thoroughly that neither the safety of its employees or agents, nor the safety or usefulness of any products, will be jeopardized by any procedure selected.

SERVICE INFORMATION:

Service Bulletins are issued to supplement or supersede information in the Van Hool manuals. Note Service Bulletin number, date and subject on the register at the end of the relevant chapter(s). File Service Bulletin separately for future reference.